

# ST2043 PoE+ Door Central

Article No. 200-003

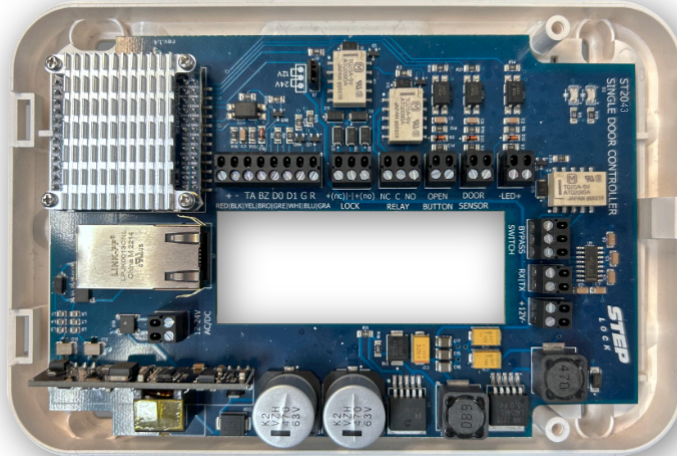

## Disclaimer

*This user manual serves as a resource for users to operate and maintain the product effectively. It is not designed to cover all aspects of the product or its usage comprehensively. The manufacturer or publisher accepts no liability for any inaccuracies or omissions in this manual.*

---

<b>1. Introduction.....</b>	<b>4</b>
<b>2. Overview of PCB-board.....</b>	<b>4</b>
2.1. Status LED indicators .....	5
2.2. Power option.....	6
2.2.1. J12 - AC/DC External Power Source .....	6
2.2.2. PoE+ .....	7
2.2.3. J3 - Strapping pin .....	8
2.2.4. Power budget .....	8
2.3. Outputs.....	9
2.3.1. J2 - Lock Output .....	9
2.3.2. J7 - Relay Output.....	10
2.3.3. U6 - Power Output.....	11
2.3.4. J14 - Bypass switch .....	12
2.4. Inputs .....	13
2.4.1. J4 LED +/- .....	13
2.4.2. J5 - Open button .....	14
2.4.3. J1 - Door sensor.....	15
2.5. Additional.....	16
2.5.1. U8 - Reader.....	16
2.5.2. U2 - RX TX.....	18
<b>3. Step-by-step installation.....</b>	<b>19</b>
3.1. Preparation.....	19

---

3.1.1. Software preparation.....	19
3.1.2. Cable preparation.....	19
3.1.3. Tools, cables and plugs.....	20
3.1.4. Physical Installation.....	21
3.1.5. Placement / Mounting.....	21
3.2. Connecting electronic lock.....	22
3.2.1. Fail Secure .....	22
3.2.2. Fail safe.....	23
3.3. Connecting opening button.....	24
3.4. Connecting swing door operator.....	25
3.5. Reader .....	27
3.5.1. Overview of the reader.....	27
3.5.2. Connecting main reader .....	29
3.5.3. Auxiliary reader.....	31
3.5.4. Alarm.....	32
3.6. Use of shielded cables .....	33
3.7. Powering ST2043 .....	34
3.7.1. Powering the ST2043 using J11 PoE+ .....	34
3.7.2. Powering the ST2043 using J12 - power input.....	35

---

## 1. Introduction

This article provides instructions for setting up, installing, using, and maintaining the ST2043 PoE+ Door Central.

**NOTE:** There are two versions of the ST2043; PoE+ and LTE. This article only applies to the pOe+ version. For information on the LTE version, please refer to the User Manual ST2043 LTE Door Central.

## 2. Overview of PCB-board

Following is an overview of the PCB board for the ST2043 PoE+ Door central.

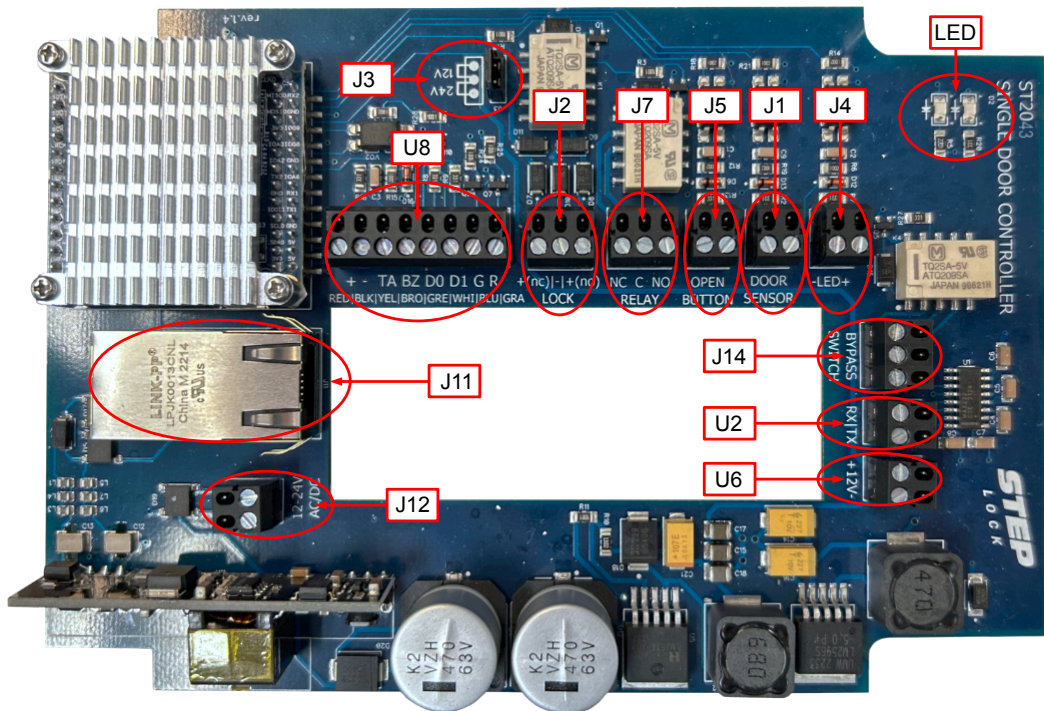

SA00201A Fig.001

## 2.1. Status LED indicators

The ST2043 PCB board is equipped with two status LED indicators that provide important information about the device's status;

- The first indicator, LED1, blinks green when the firmware is successful running. This indicator should blink approximately every five seconds. If LED1 does not blink, it may indicate an issue with ST2043's firmware.
- The second LED indicator, LED2, remains a solid green colour when the ST2043 device is powered and functioning correctly. This indicator provides reassurance that the device is operating as intended.

**NOTE:** It is essential to note that there are no other colours or blinking patterns used for these LED indicators to signify different states.

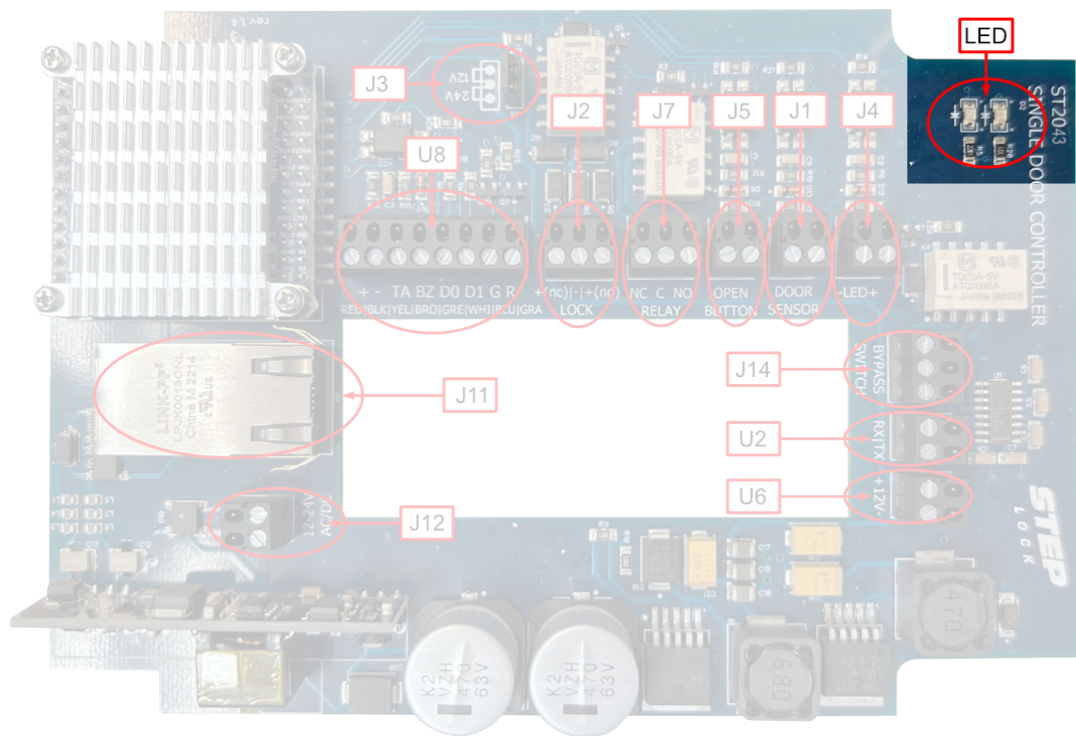

SA00201A Fig.002

## 2.2. Power option

### 2.2.1. J12 - AC/DC External Power Source

The J12 input is a connection point for an external power source, which can be either alternating current (AC) or direct current (DC). This input allows the ST2043 PoE+ to be powered by an external power supply.

The acceptable range for input voltages is between 12 volts and 24 volts. This means that any voltage within this range can be safely used to power the device.

**NOTE:** It is important to note that using a voltage outside of this range may cause damage to the device and should be avoided. Additionally, it is recommended to use a power supply that is balanced and ripple-free, with a minimum capacity of 2 amperes. **Take care to choose a power supply that is suited for fine electronic circuitry.**

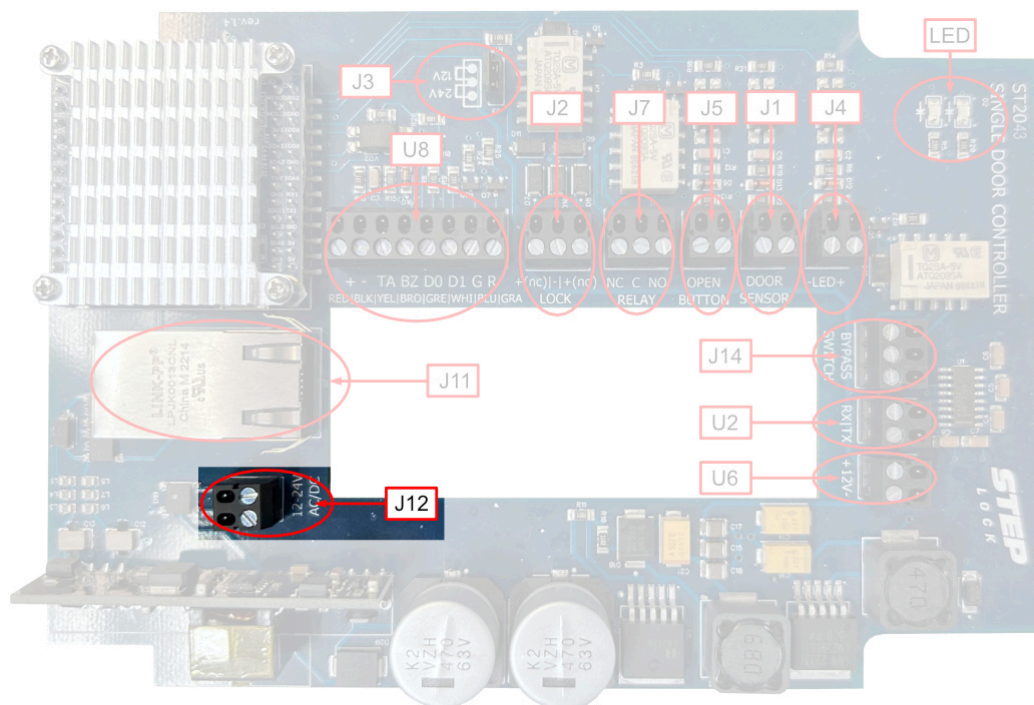

SA00201A Fig.003

### 2.2.2. PoE+

The ST2043 PoE+ control board can be efficiently powered using the PoE+ (Power over Ethernet) IEEE 802.3at standard. This allows for the simultaneous transmission of both data and electrical power over a single Ethernet cable, simplifying the installation process and reducing the need for additional power cables or outlets.

**NOTE:** Under the IEEE 802.3at PoE+ standard, each PoE+ enabled port can deliver up to 30 watts of power.

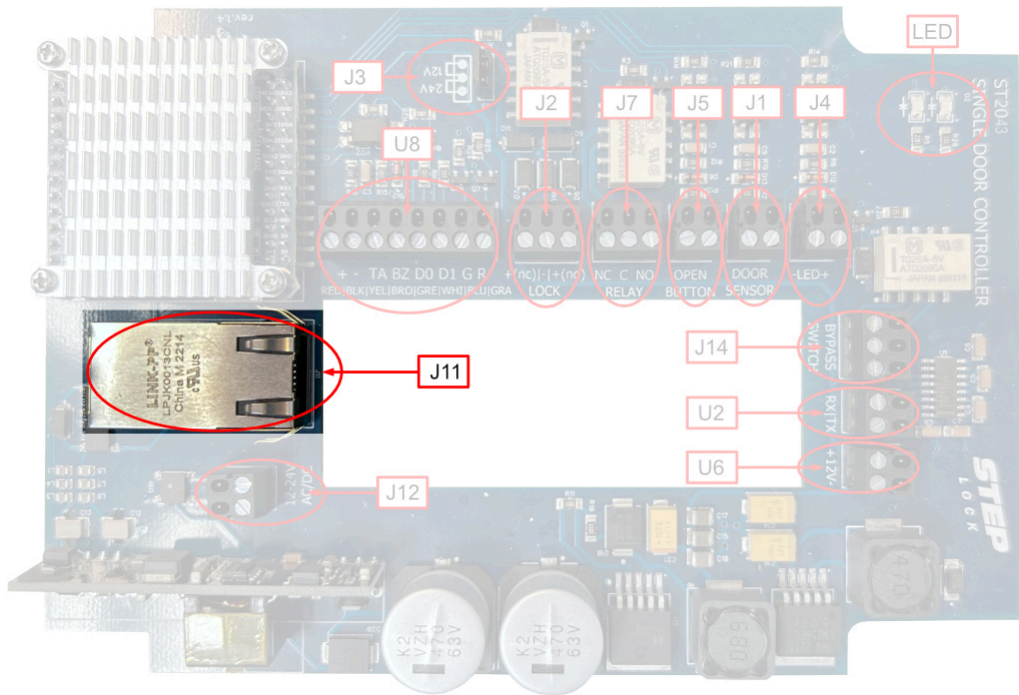

SA00201A Fig.004

### 2.2.3. J3 - Strapping pin

The J3 strapping pin is in charge of adjusting the power output for the "J2 - Lock output". The J3 pin has two options: 12 volts and 24 volts.

**NOTE:** It is important to note that if the ST2043 PoE+ is powered by an external 12-volt power supply, the strapping pin can not be set to 24 volts. This is because the PCB board is equipped with step-down regulators only.

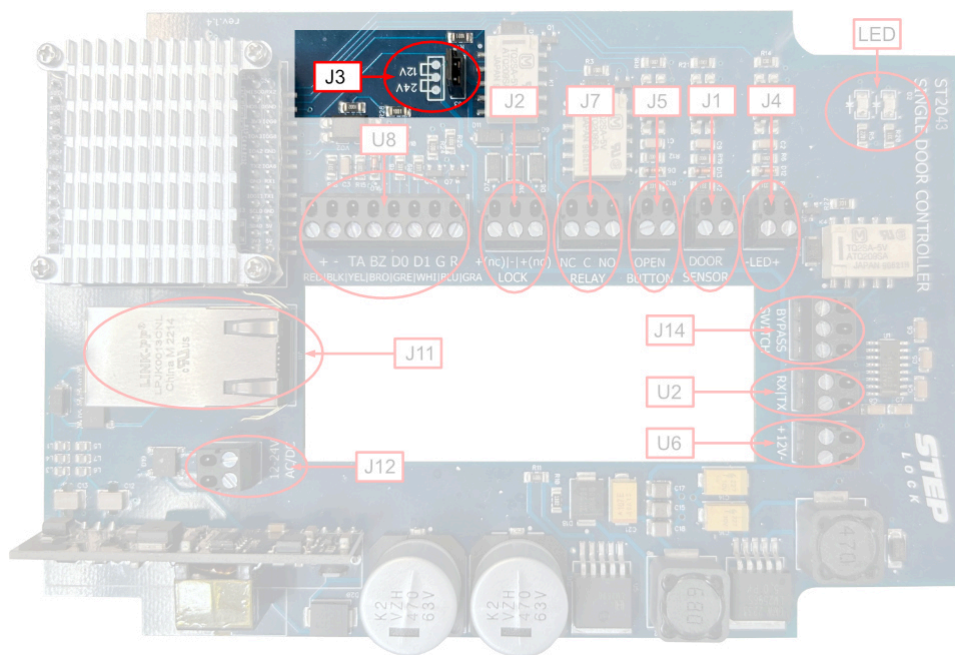

SA00201A Fig.005

### 2.2.4. Power budget

**NOTE:** It is important to note that all the measurements provided are specifically for the ST2043 PoE+ Door Central and includes the card reader.

When using the ST2043 PoE+, the power consumption will depend on the voltage used to power the device. If the ST2043 PoE+ is powered using a 24-volt supply, it will consume approximately 150 milliamperes (mA) of current. Conversely, if a 12-volt supply is used, the ST2043 PoE+ will require approximately 300 mA of current.



## 2.3. Outputs

### 2.3.1. J2 - Lock Output

The pins on the "Lock-relay" are identified with the labels "+(nc) | - | +(no)". In practical terms, if you have a fail-secure electronic lock setup, you would need to connect the "+" wire to the right pin "+(no)". Conversely, if you have a fail-safe configuration, the "+" wire should be connected to the left pin "+(nc)".

**NOTE:** It is important to note that the correct wiring configuration depends on the type of electronic lock used. A fail-secure configuration locks the door in the event of a power failure, while a fail-safe configuration unlocks the door in the same situation. Therefore, it is crucial to identify the correct wiring configuration for the specific lock used to ensure proper operation and security.

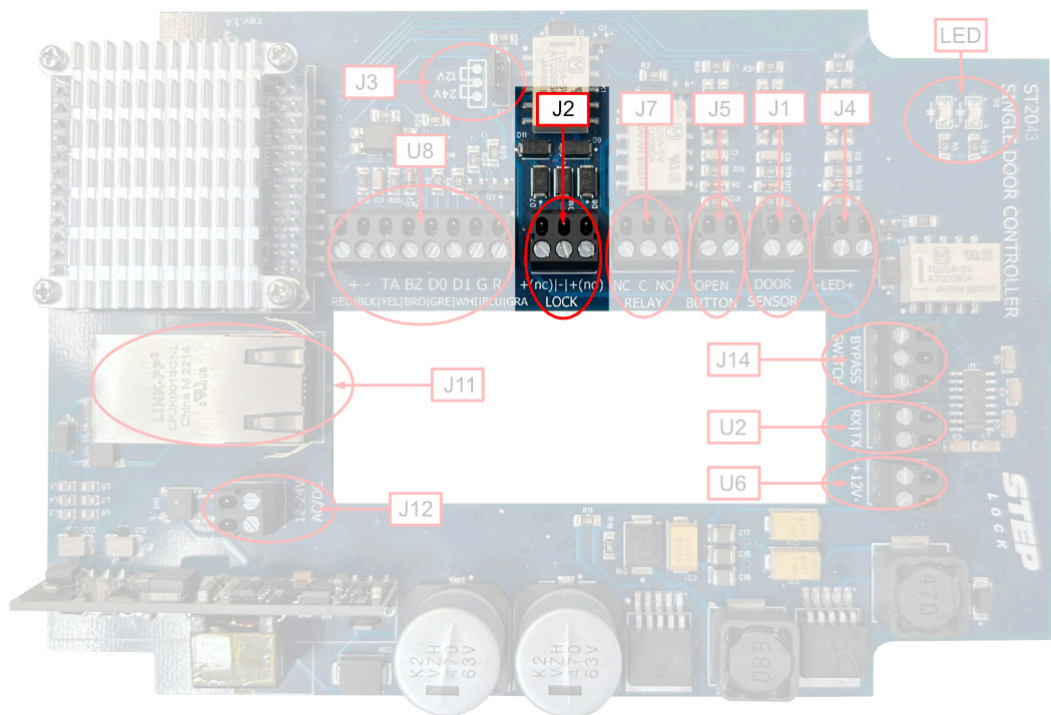

SA00201A Fig.006



### 2.3.3. U6 - Power Output

U6 is a power output port that is explicitly designed to provide a stable power source for external accessory devices only. This output enables you to power secondary card reader.

The use of U6 enables external accessory devices to draw power from the ST2043 PoE+, eliminating the need for a separate power supply. This can be beneficial in situations where you -for example - have an exit button that requires power.

**NOTE:** It is important to note that U6 is designed to output direct current (DC) 12v power only.

**IMPORTANT:** It is important to note that U6 is not intended for cascading connections, meaning it is not designed to be used as a power supply for other devices or systems.

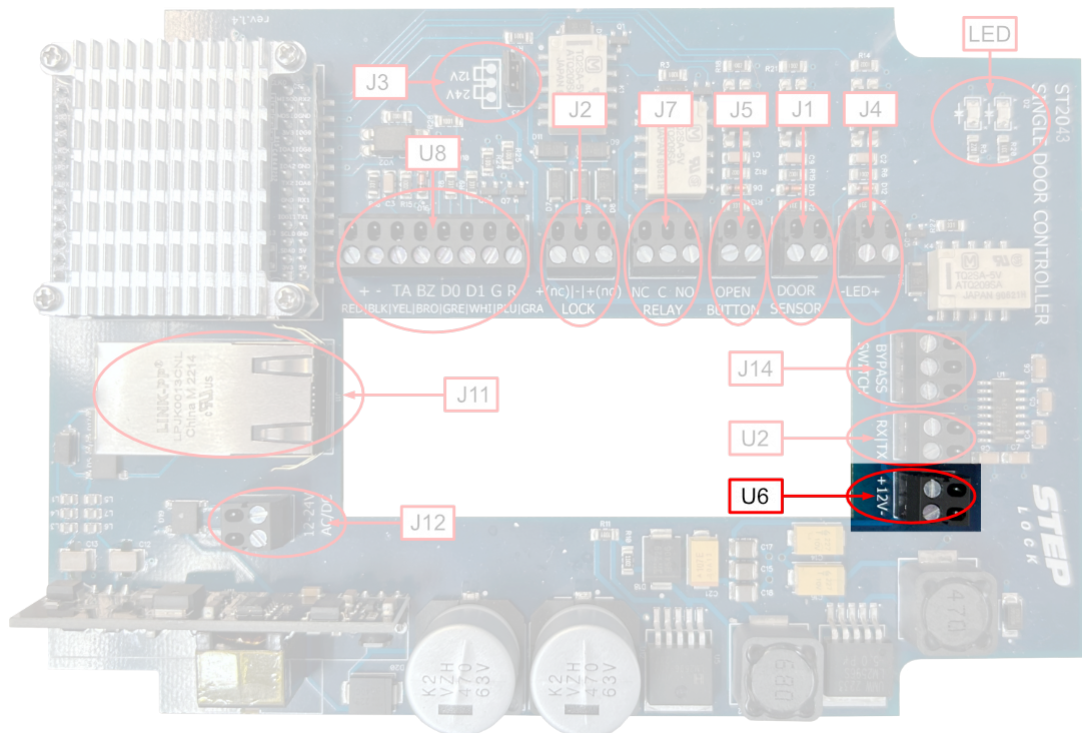

SA00201A Fig.008

### 2.3.4. J14 - Bypass switch

The J14 - Bypass Switch is a dedicated trigger relay switch designed for controlling a single alarm zone. This switch allows you to bypass an external alarm for the specified zone.

Please be aware that the J14 - Bypass Switch is designed to control only one zone at a time. To manage multiple zones or customise zone controls, consult the appropriate sections in the alarm system's user manual. Configuration of these functions must be performed within the alarm system itself to ensure proper operation and security.

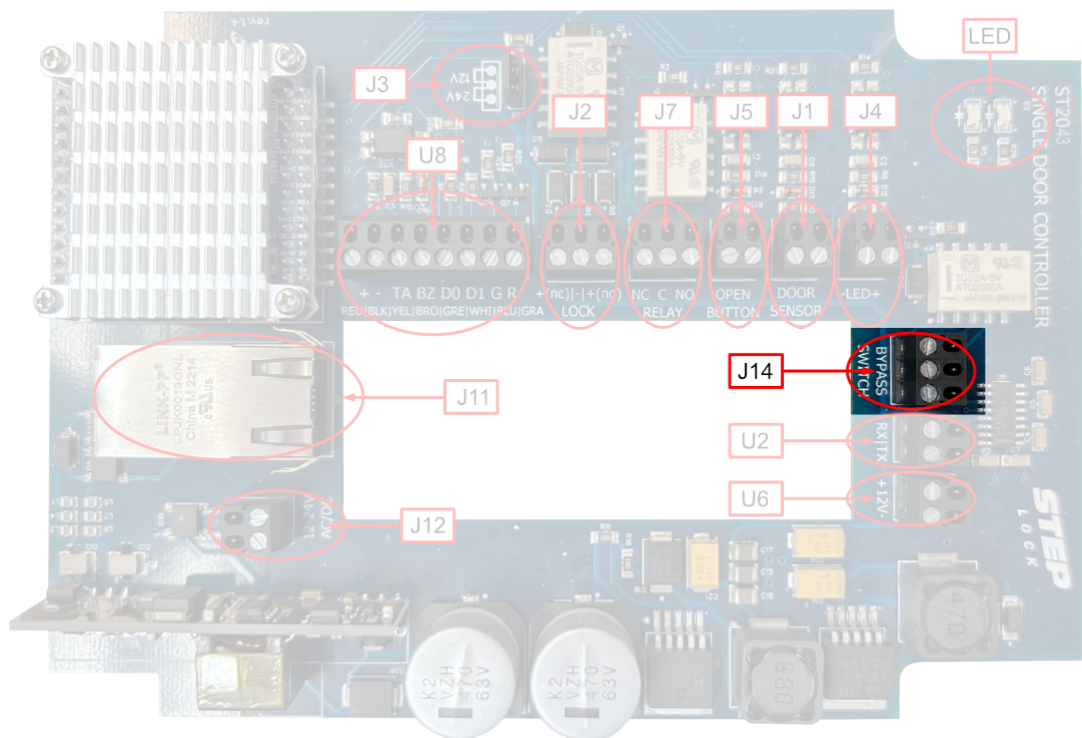

SA00201A Fig.009

## 2.4. Inputs

### 2.4.1. J4 LED +/-

The J4 input serves as a monitoring point for the activation or deactivation of the alarm system. By linking the suitable sensor or signal to the J4 input, users can effectively monitor the alarm's operational status in real-time. The input is designed to accept a voltage range of 5V to 12V DC, ensuring compatibility with various alarm system configurations.

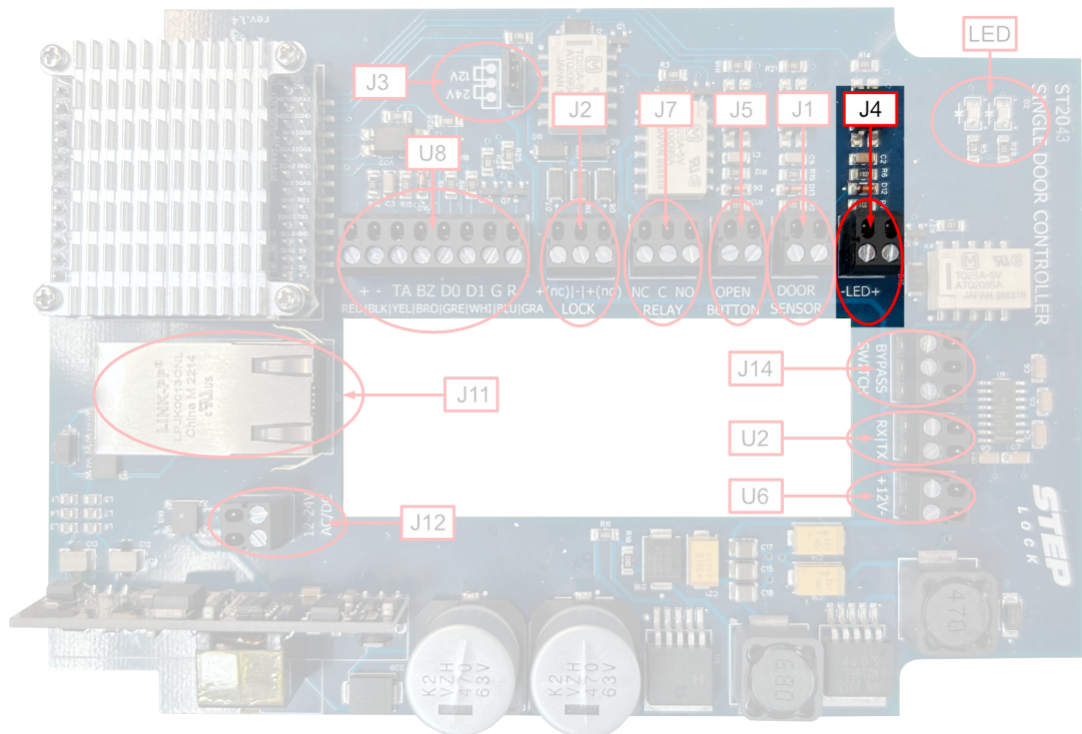

SA00201A Fig.010

## 2.4.2. J5 - Open button

The J5 port, also known as the Open button input, is designed to trigger both the J7 Relay output and the J2 Lock output simultaneously when activated. This means that when the J5 port is triggered, it will result in the immediate activation of the J7 and J2 ports.

This functionality can be useful for controlling the access to a specific area, as it enables the device to unlock the door and activate additional systems or devices simultaneously. For instance, it could be used to activate a camera system or a notification system to alert security personnel.

**NOTE:** It is important to note that triggering the J5 port will cause an immediate and simultaneous activation of the J7 and J2 ports. Therefore, it is recommended to use this feature carefully and with proper consideration of the potential consequences.

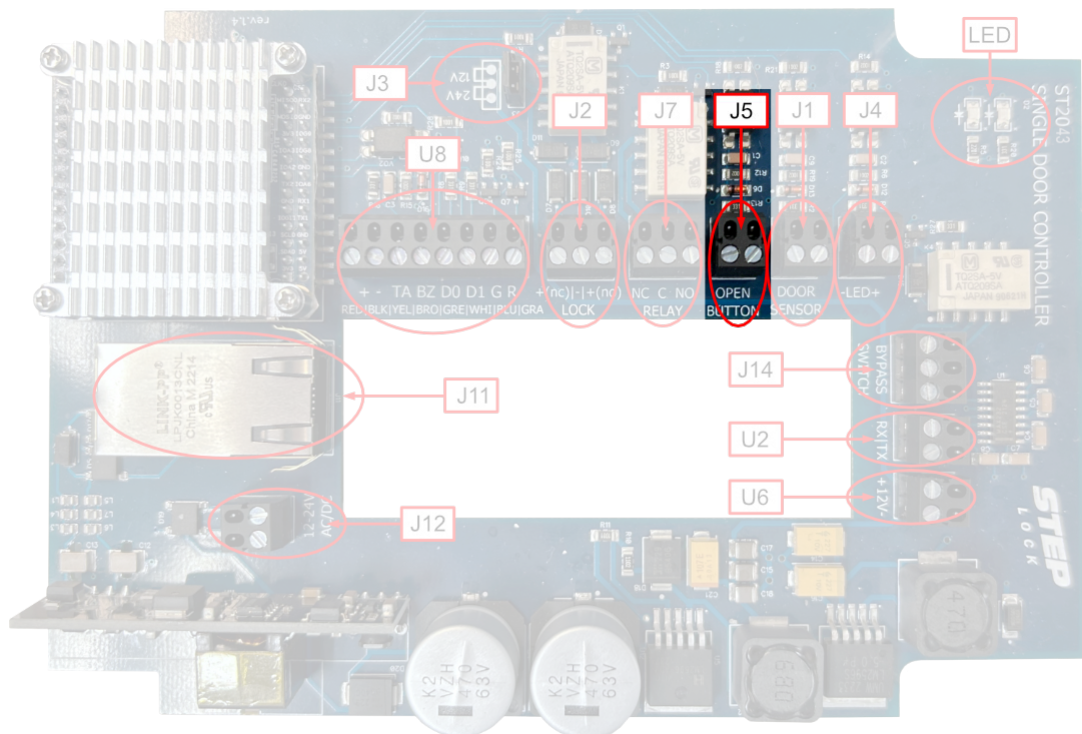

SA00201A Fig.011

### 2.4.3. J1 - Door sensor

By connecting the door sensor to the J1 input, users can effectively monitor the opening and closing events of doors in real-time.

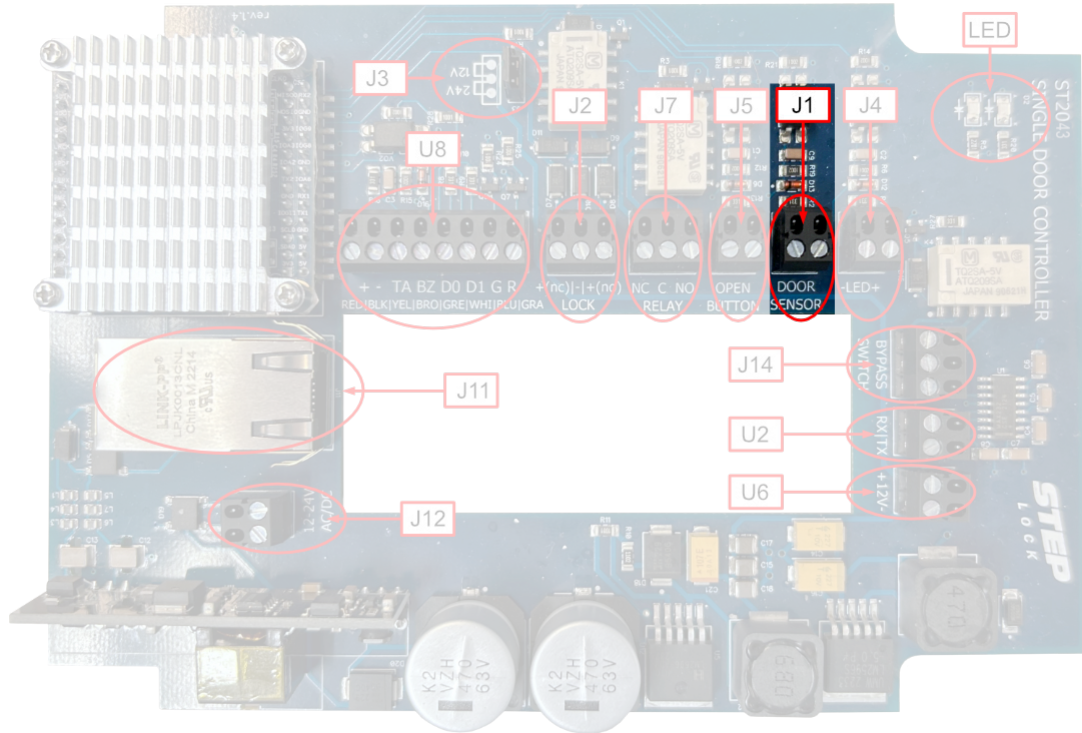

SA00201A Fig.012

## 2.5. Additional

### 2.5.1. U8 - Reader

The U8 Reader serves as the primary input component for the main card reader, facilitating seamless data transfer and processing.

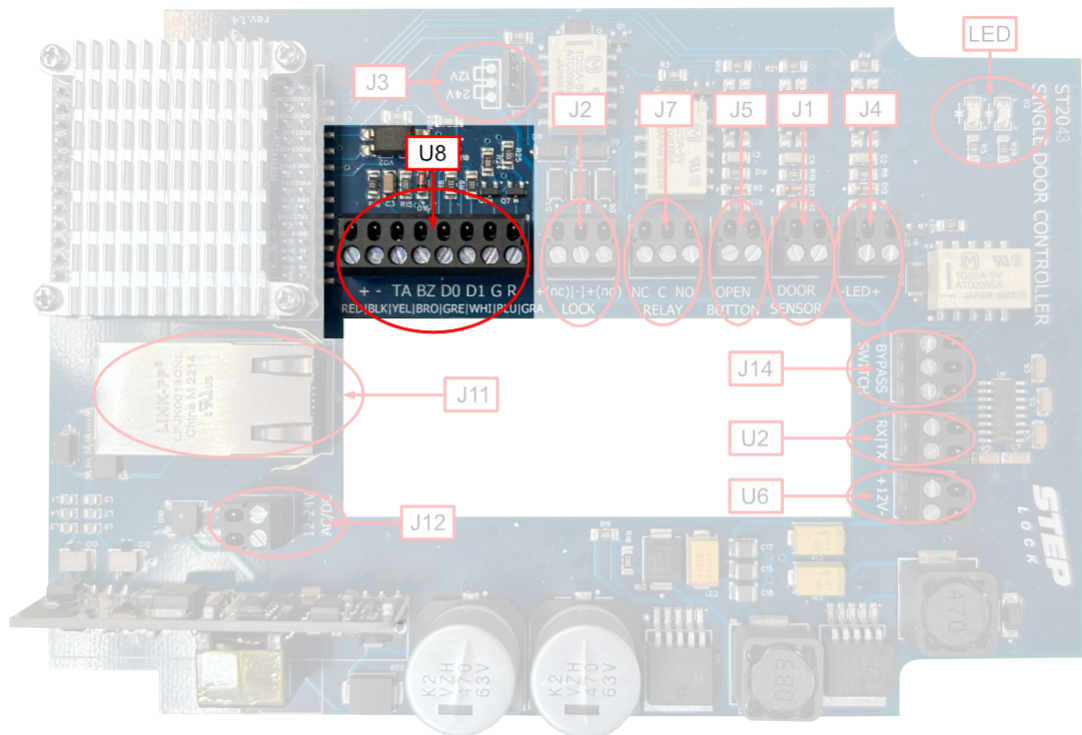

SA00201A Fig.013

This input features a colour-coded connection pin system to ensure proper configuration and functionality. The pins are assigned as follows:

**Red:** This pin is responsible for providing 12 volts of power to the card reader.

**Black:** This pin serves as the ground connection, offering a stable reference point for the electrical circuit.

**Yellow:** The tamper pin detects any unauthorised access or tampering with the card reader, ensuring optimal security.



**Brown:** This pin is connected to the buzzer, which produces audible alerts or notifications during operation.

**Green:** The D0 pin is responsible for handling data communication between the card reader and the connected device.

**White:** Similar to the green pin, the D1 pin also manages data communication, allowing for efficient data processing.

**Blue:** This pin is connected to the red LED, which serves as an indicator light for various operational statuses.

**Grey:** The grey pin is linked to the green LED, which also functions as a status indicator for the card reader.

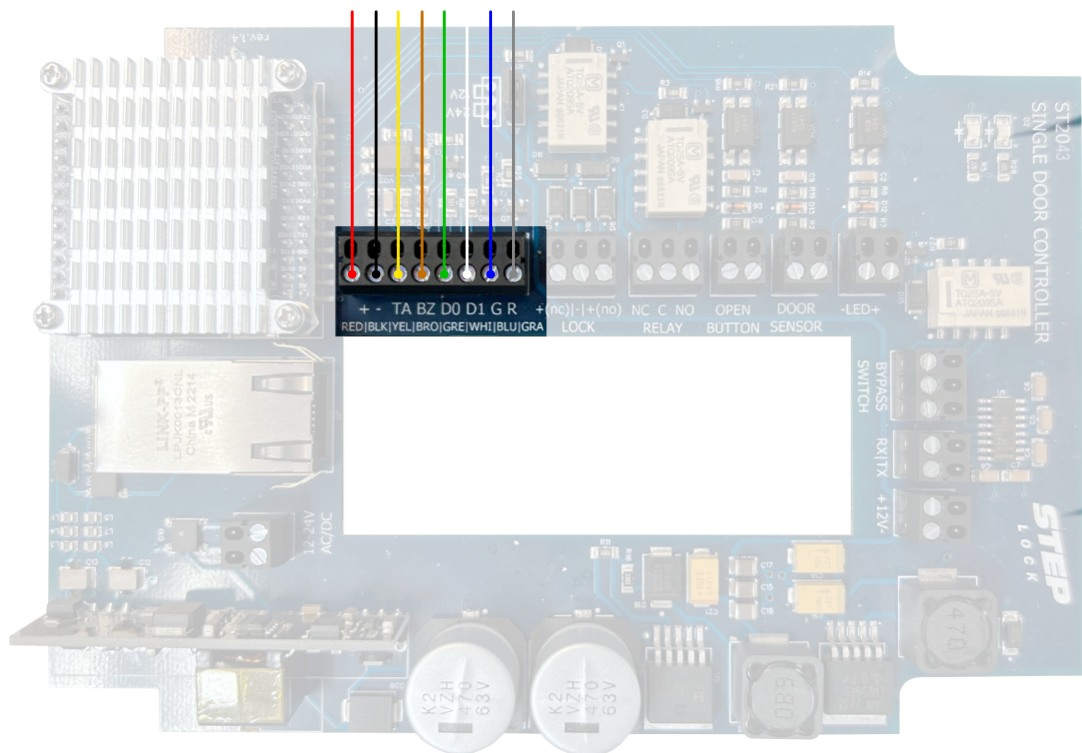

SA00201A Fig.014

### 2.5.2. U2 - RX|TX

The U2 - RX | TX input/output is used for communicating with the second reader. Using Wiegan protocol.

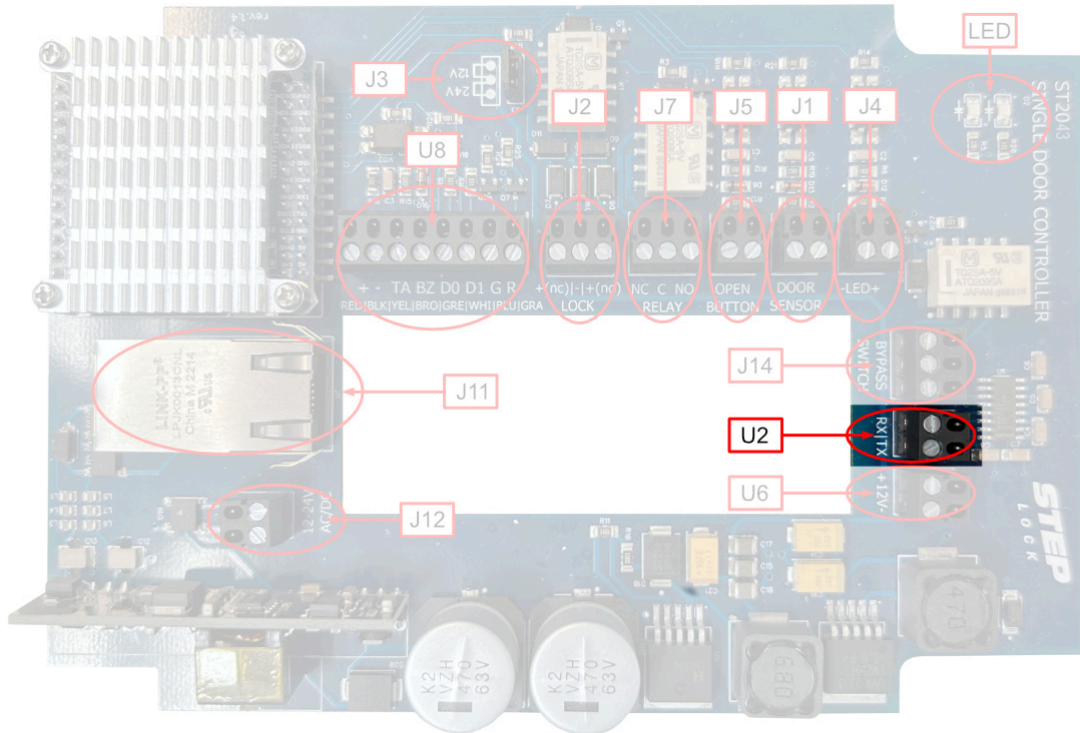

SA00201A Fig.015

### 3. Step-by-step installation

**WARNING:** Only power on the ST2043 PoE+ once you have carefully read and understood these instructions and confirmed that the unit is properly connected. Failure to follow these instructions may result in damage to the product and render it inoperable.

#### 3.1. Preparation

##### 3.1.1. Software preparation

Before installing the ST2043 PoE+ Door Central, it is important to ensure that the following tasks have been completed in Steplock Cloud:

- Create a Cloud tenant for the end customer. This tenant will serve as a platform for managing and monitoring the ST2043 device and its associated components.
- Create a Property within the end customer's Cloud tenant. This will allow the end customer to manage and monitor the ST2043 device and its associated components within a specific location.
- Add the MAC address of the ST2043 intercom to the end customer's Cloud tenant. This will ensure that the access system is properly integrated and is able to function effectively.

##### 3.1.2. Cable preparation

Prior to installing the ST2043 PoE+ Door Central, it is crucial to ensure that all necessary cables are properly installed in the door location.

The first cable required is a CAT 6 cable for the connection between the ST2043 and the PoE+ enabled switch. This cable provides power and Ethernet connectivity for two-way communication between the ST2043 and the Cloud. To ensure proper installation, it is recommended to test the CAT 6 cable with a network tester to confirm that it is working correctly.

In addition to the CAT 6 cable, standard wiring is required to connect the electronic lock, exit button, and other related components to the ST2043. It is important to install these cables securely to prevent any complications or errors during the installation process.

**Note:** When using an external power supply for the ST2043, it's advisable to verify that the incoming power is within the recommended range. By doing so, you can prevent potential power-related issues and ensure the device operates smoothly and efficiently.

### 3.1.3. Tools, cables and plugs

Being well-prepared with the necessary equipment can facilitate a smooth and efficient setup, reducing the likelihood of encountering issues or delays. Some of the tools you may want to have on hand for a seamless installation include:

- A high-quality RJ45 termination tool is indispensable for a successful installation. This tool guarantees a secure and accurate termination of the CAT6 cable to the RJ45 plug, which is vital for establishing a stable and reliable connection between the ST2043 and the PoE+ enabled switch.
- An RJ45 network cable tester is essential for evaluating the CAT6 cable after termination. This instrument helps verify that the cable has been correctly terminated and is functioning as intended, ensuring the integrity of the connection.

**Note:** It's essential to use high-quality RJ45 plugs for secure and accurate terminations, as this contributes to stable and reliable connections. Be sure to use short plugs to maintain optimal performance and connectivity.

- CAT6 cable, either shielded or unshielded, is required for the connection between the ST2043 and the PoE+ enabled switch. The choice of shielded or unshielded cable depends on the specific installation environment and requirements.

### 3.1.4. Physical Installation

**NOTE:** It is crucial to verify that all cables are installed properly and securely to prevent any potential complications or errors during the installation process. It is recommended to visually inspect all cables and use a network tester to confirm that the cables are in good working condition before proceeding with the installation. This will help to prevent any potential issues that may arise due to faulty or improperly installed cables.

**IMPORTANT:** Always remove power to the ST2043 before connecting devices or accessories to it.

### 3.1.5. Placement / Mounting

One common location for mounting the ST20243 is above the door, as this is typically where most of the electronic lock, exit button, and door operator connections are located.

## 3.2. Connecting electronic lock

### 3.2.1. Fail Secure

To configure the ST2043 for fail secure mode, connect the positive (“+”) wire to the right pin “+(no)” of the J2 Lock Output and the negative (“-”) wire to the middle pin of the J2 Lock Output, as shown below. Take care to set the strapping pin to the correct voltage of the lock.

**Note:** When powering the ST2043 through the J12 power input using a 12V supply, it's important to remember that you cannot set the strapping pin to 24V. This is because the ST2029 is equipped with step-down regulators exclusively, which do not allow for an increase in voltage.

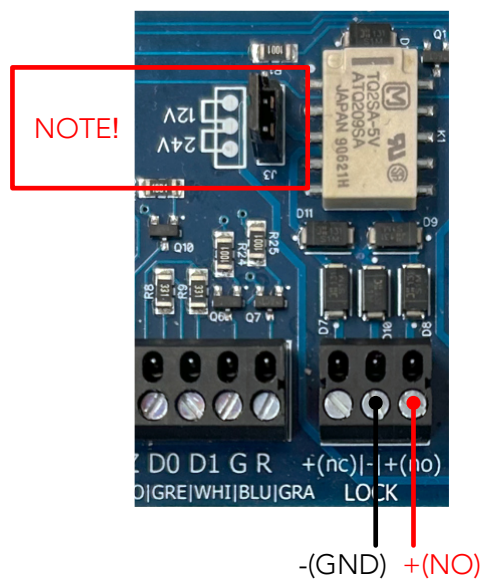

SA00201A Fig.016

### 3.2.2. Fail safe

To configure the ST2043 for fail-safe operation, connect the positive (+) wire to the left pin "+(nc)" on J2 Lock Output and the negative (-) wire to the middle pin (-) of J2 Lock Output. This wiring configuration ensures that the door will remain unlocked in the event of a power failure, allowing for safe exit from the building.

Note: When powering the ST2043 through the J12 power input using a 12V supply, it's important to remember that you cannot set the strapping pin to 24V. This is because the ST2029 is equipped with step-down regulators exclusively, which do not allow for an increase in voltage.

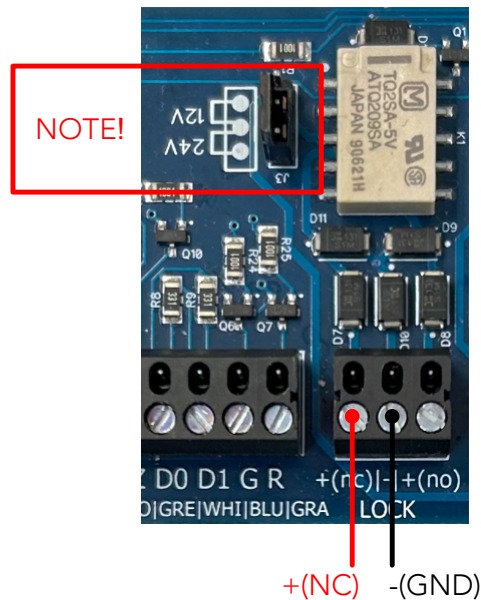

SA00201A Fig.017

**NOTE:** If electronic locks other than Steplock are being used, it is recommended to install a protection diode (e.g. 1n4004) between the electronic lock and the output.

### 3.3. Connecting opening button

Connecting the exit/open button to the ST2043 is a simple process. Pin A and pin B should be connected to the exit button. If the exit/open button requires 12V power, it can be supplied separately using the U6 - Power output.

**NOTE:** It is important to be aware that if you plan to use an additional card reader, the U6 will be the source of power for that device. As a result, the U6 will be solely responsible for providing power to the card reader, and cannot be utilised to power any other accessories at the same time. It is crucial to plan your power consumption carefully to ensure that you have enough power available for all the devices you need to use.

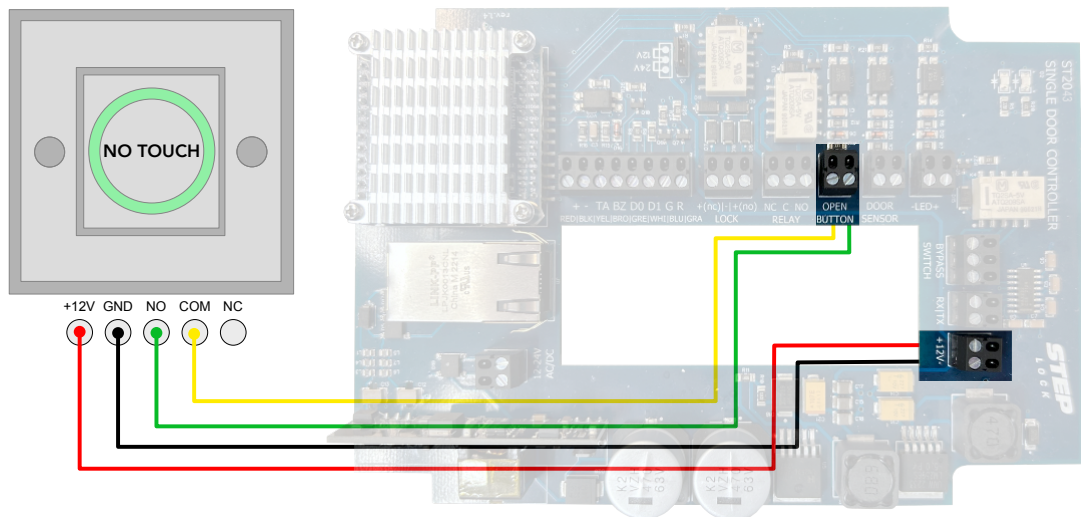

SA00201A Fig.018

- Connect the +12V (RED) from the exit button to the left pin "+" on U6.
- Connect GND (BLACK) to the right pin "-" on U6.
- Connect NO (GREEN) to right pin on J1
- Connect COM (YELLOW) to left pin on J1



### 3.4. Connecting swing door operator

If you intend to use the J4 Relay output to trigger a door on a "open door schedule" with swing door operator, you'll need to add an external relay to the system. This is a necessary to prevent constant triggering of the swing door operator and keeping the door open all the time.

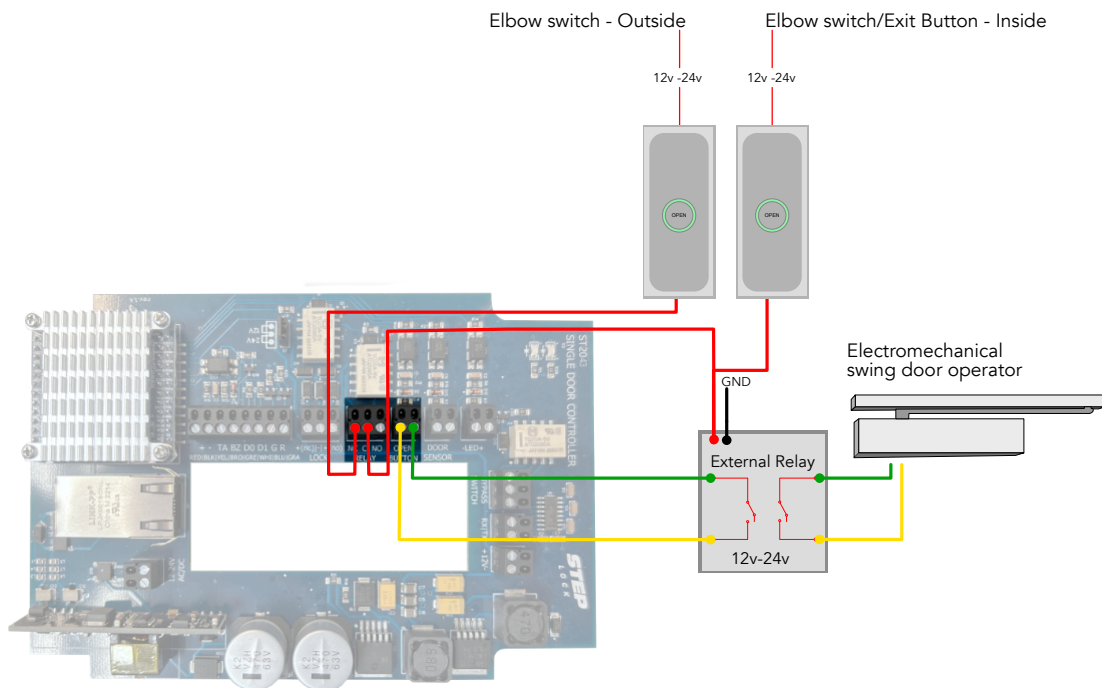

SA00201A Fig.019

Ensure that both elbow switches receive power. Use an external power source for powering them.

To connect the system;

- Connect the elbow switch on the outside to the normally closed (NC) contact of the J7 relay output.
- Connect the common (C) contact of J7 relay output to the power input of the external relay.
- Connect the elbow switch/exit button on the inside to the power input of the external relay.

- The J5 - Open button should be connected to the output of the external relay,
- Connect the swing door operator to the secondary output of the external relay.

**NOTE:** This particular system configuration is designed to enable the door to stay closed yet unlocked during an open door schedule. When the door is in a locked state, it is necessary to use the elbow switch to activate the swing door operator after successfully scanning an access card or tag.

### 3.5. Reader

#### 3.5.1. Overview of the reader

The card reader is segmented into several distinct sections. These include:

- **LED Status Indicator:** This feature provides visual cues using lights to signal the reader's current status. There are two colours used - green and red. A red light signifies that a card or tag has been declined or is unauthorised. A continuous red light indicates that the alarm has been set. On the other hand, a green light is a positive signal, indicating that access has been granted.
- **Keypad:** This section allows manual data entry. Users can input their personal identification number (PIN) or other codes as required. The keypad is essential for additional security, especially when used in combination with the card or tag reader.
- **Tag or Card Reader Area:** This is the section where cards or tags are scanned. When a card or tag is presented, the reader captures the information embedded in the card or tag. compatible with multiple card technologies such as MiFare Classic, Ultralight, Desfire, Ev1, and Ev2.



SA00201A Fig.020

To open the reader, begin by locating the hex nut, which is situated at the bottom of the device. You will find a hex key included in the package, designed specifically for this purpose.

Use the provided hex key to unscrew the hex nut. Once the nut is removed, you're able to disengage the back cover of the reader. Start this process from the bottom, where the nut was, and move upward.



SA00201A Fig.021

Upon successfully detaching the back cover, you'll gain access to the inner workings of the reader. Inside, you will discover three main components of interest:

- **Connection Point for the ST2029 Cable:** This is the specific interface where the cable connecting the reader to the ST2029 is attached. It's crucial to ensure that this connection is secure and properly inserted for optimal functioning.
- **Speaker:** The built-in speaker is an integral part of the reader's feedback system. It produces audio signals or tones, aiding in the user interface by providing auditory feedback, such as confirming a successful card read or signalling an error.
- **Tamper Switch:** This is a security feature designed to detect and alert in case of any unauthorised attempts to open or interfere with the reader. If the device is tampered with, the switch is triggered, resulting in an alarm.

- DIP-switch: The DIP switch consists of two individual switches, referred to as DIP1 and DIP2.
- DIP1 serves the purpose of maintaining a constant illumination of the LED (Light Emitting Diode), ensuring it remains on at all times.
- DIP2 is responsible for managing the volume settings of the card reader. Within DIP2, you have the option to select between low and high volume levels.

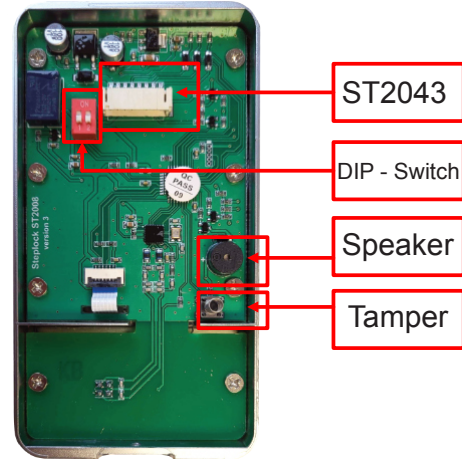

SA00201A Fig.022

### 3.5.2. Connecting main reader

To establish a connection on the card reader, use the cable with the 8 Pole PHR8 connector. This should be inserted into the pin-set located on the back of the PCB in the card reader. It's essential to ensure that the flat connector is fully inserted; to achieve this, apply even pressure on both sides of the connector simultaneously. This balanced push will ensure a secure and proper connection.

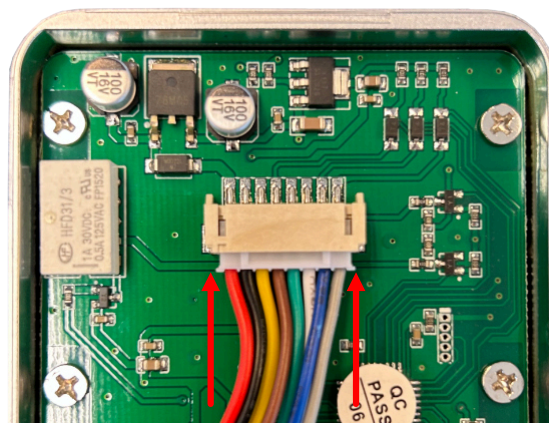

SA00201A Fig.023

After the flat connector is firmly seated in the pin set on the reader, you can proceed to connect the free ends of the wires to the connector pins on the ST2042.

To properly set up a connection between the primary reader and the ST2043, it's imperative that each wire, identified by its unique colour, is matched and connected to its corresponding pin. These wires and pins have been colour-coded to simplify the process and reduce the risk of incorrect connections. Here is an elaborated description of each colour-coded pin:



SA00201A Fig.024

**Red:** This pin is responsible for providing 12 volts of power to the card reader.

**Black:** This pin serves as the ground connection, offering a stable reference point for the electrical circuit.

**Yellow:** The tamper pin detects any unauthorised access or tampering with the card reader, ensuring optimal security.

**Brown:** This pin is connected to the buzzer, which produces audible alerts or notifications during operation.

**Green:** The D0 pin is responsible for handling data communication between the card reader and the connected device.

**White:** Similar to the green pin, the D1 pin also manages data communication, allowing for efficient data processing.

**Blue:** This pin is connected to the red LED, which serves as an indicator light for various operational statuses.

**Grey:** The grey pin is linked to the green LED, which also functions as a status indicator for the card reader.

### 3.5.3. Auxiliary reader

In order to incorporate an auxiliary or secondary reader into your access control system, you will need a couple of additional components. The first one is, of course, the secondary reader itself. The second component required is the '150-005 Wiegand Expansion Module for In/Out Reader'. This module is designed specifically to enable the functionality of a secondary in/out reader within the system.

After acquiring these components, you would begin the connection process. This involves linking specific points on the expansion module to corresponding points on the ST2043 controller. Here's a step-by-step guide on how to do this:

Locate the "U6 -12+/-" connection point on the Wiegand expansion module. This point needs to be connected to the corresponding "U6 -12+/-" point on the ST2043 controller.

Next, find the "U7 - TX|RX" connection point on the expansion module. This needs to be connected to the "U2 - TX|RX" point on the ST2043 controller.

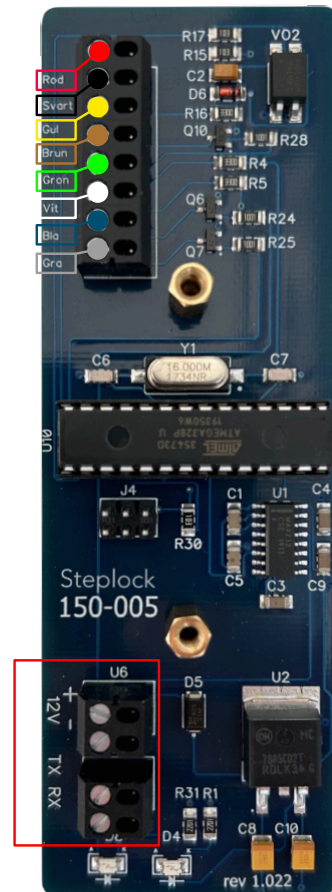

SA00201A Fig.025

### 3.5.4. Alarm

The J14 - Bypass Switch serves as a unique trigger relay switch devised for managing a solitary alarm zone. This switch facilitates the bypassing of an external alarm within the assigned zone. You can use it to activate or deactivate an alarm in your system.

Please note that the J14 - Bypass Switch is engineered to handle a single zone at any given moment. If you need to oversee multiple zones or wish to personalise zone controls, refer to the specific sections in the alarm system's user manual. The configuration of these functionalities must be carried out within the alarm system to guarantee correct operation and maintain security.

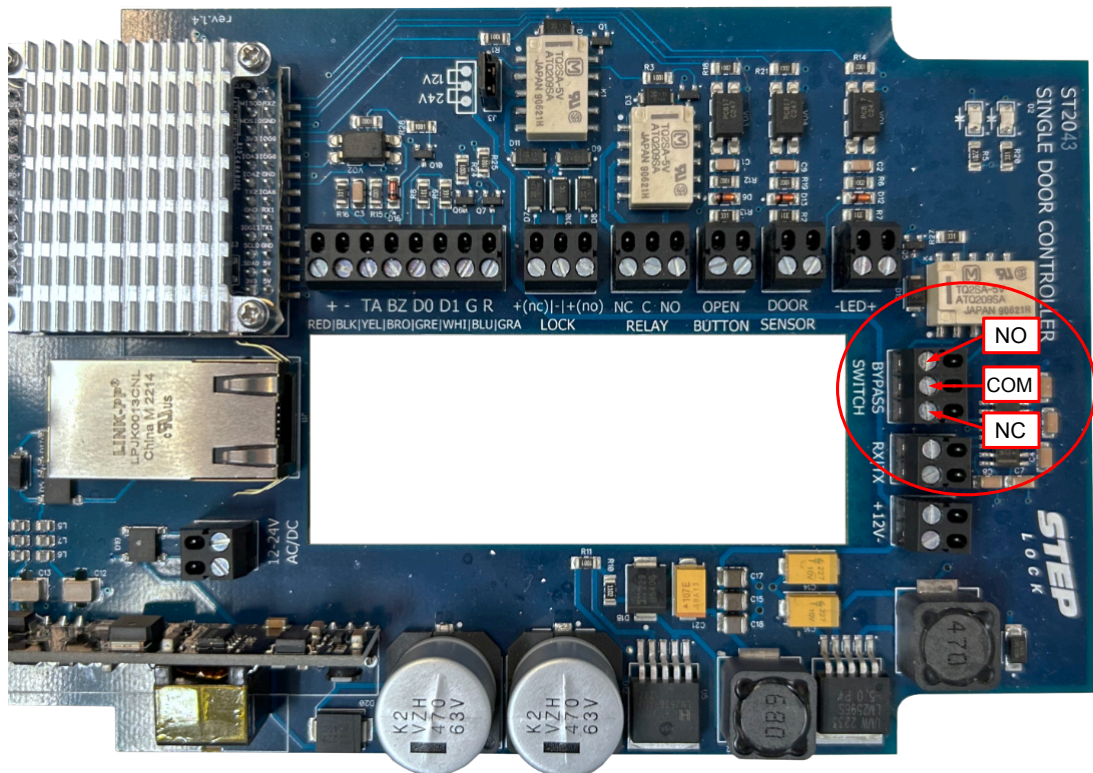

SA00201A Fig.026



### 3.6. Use of shielded cables

The card reader is accompanied by a shielded cable. This particular type of cable has a protective layer that is designed to prevent interference from external factors. This feature becomes particularly useful in environments where there is a significant presence of electromagnetic or radio frequency interference, which can disrupt the performance of electronic devices.

For instance, in industrial settings, there are often many machines and devices operating simultaneously, each generating their own electromagnetic fields. These fields can interfere with the data transmission of unshielded cables, potentially leading to data corruption, false log entries or loss of data. By utilising a shielded cable, the card reader is able to maintain reliable and accurate data transmission, even in such challenging conditions.

The shielded cable that comes with the card reader is a 15 meter ready made cable that terminates in a ring that is screwed into the base plate of the reader. It is important to properly ground the cable.

The opposite terminal of a shielded cable is typically attached to a The opposite end of a shielded cable is usually connected to a grounding point, although the specific manner of this connection can vary significantly depending on the particular installation. It is the responsibility of the installer to identify the most appropriate method to establish this ground connection for the shielded cable in each unique setting.

**NOTE:** You should also consider using a shielded CAT 6 cable from the ST2043 to the Switch as well.

### 3.7. Powering ST2043

**IMPORTANT:** Take extra care to measure the total power budget on your setup and configuration.

When planning your power usage, don't forget to consider additional factors such as the electronic lock and whether you'll be using the U6 power output. It's crucial to calculate your total power budget to ensure that you have enough voltage and amperage to meet your needs.

**IMPORTANT:** If you have connected other units to the ST2043 then check the strapping pin on J2 before powering the ST2043, to ensure that you have correct voltage to the electronic lock.

#### 3.7.1. Powering the ST2043 using J11 PoE+

To provide power to the ST2043 device via Power over Ethernet Plus (PoE+), you must first ensure you have a switch that supports PoE+ technology. PoE+ is a network feature that allows electrical power and data to be carried over the same Ethernet cable, providing an efficient and simplified method of powering network devices.

You will need a network cable of CAT6 grade or higher to establish a connection between the switch and the ST2043. This specific category of Ethernet cables is designed for high-speed networking and can also support PoE+. It's recommended to use CAT6 or a higher category due to their enhanced performance and higher power capacity compared to older types.

On the ST2043, you will find a J11 input. This is the port where you will insert the Ethernet cable coming from the PoE+ enabled switch. This connection ensures the device can communicate with the network and receive power simultaneously via the Ethernet cable.

After you've made the connection, watch the LED status indicator on the ST2043 device. It should change to green, signalling that the device is now properly powered and is successfully connected to the network via your PoE+ enabled switch. This green LED light provides a visual confirmation of the power status and network connectivity of the ST2043, ensuring it is ready for operation.

### 3.7.2. Powering the ST2043 using J12 - power input

To power the ST2043 device using the J12 power input, it is essential to use a suitable power source that meets the specific requirements of the device. This involves using an Alternating Current/Direct Current (AC/DC) power source. This type of power source is capable of supplying either form of current, giving you the flexibility to use whichever is most convenient or available in your setting.

Additionally, it is crucial to ensure that the power source is ripple-free. A ripple-free power source signifies that the output of the power supply is steady and constant, devoid of any fluctuations or 'ripples'. This is particularly important for devices like the ST2043, designed for fine electronics, as these electronics are sensitive and can be damaged by inconsistent power sources.

The power source should also have a minimum current supply capability of 2 amperes. A supply of this magnitude ensures that the device can function efficiently and that all of its electronic components receive adequate power for their operation. Please bear in mind that your overall power requirements, or power budget, might impact the choice of power supply.

One of the user-friendly features of the ST2043 device is its flexible power input design. The device can accept both positive (+) and negative (-) connections, and you have the liberty to set these as per your preference. This is made possible because the input supports both AC and DC currents, hence it can handle both polarities.

Furthermore, the device's input can support a voltage range from 12 to 24 volts. This wide range gives you the flexibility to select a power source that falls within these limits, making the device adaptable to various situations and conditions. In summary, when powering the ST2043, ensure your power source meets all these criteria to guarantee optimal operation of the device.

## Contact

**info@steplockaccess.se**

Additional support at our [website](#).

